

LSR – Requirement for quotation

Basic project



1. Customer Information

1.1 Customer:

1.2 Name:

1.3 Email-Address:

1.4 Opportunity number CRM:

A blue square containing a white 3D cube icon, positioned to the left of the section title.

2. Project Information

2.1 Project name / description:

2.2 Application:

- Automotive
- Medical
- Electronics
- Consumer

2.3 Requested delivery date:

2.4 Offer latest at:



3. Project content

3.1 What is needed:

- IMM
- Dosing equipment
- Demoulding device
- Automation
- Mould (please use RFQ form mould and automation)



4. IMM Configuration

4.1 Weights

Cavity:

Sprue:

Shot:

4.2 Cavity number:



4.IMM Configuration

4.3 Material

Supplier:

Type:

Material data sheet required

Special material requirements:



4. IMM Configuration

4.4 Mould dimensions

Width (B)

Depth (L)

Height (H)

Centre diameter:

4.5 Mould cooling

No. circuits fixed plate:

No. circuits movable plate:

4.6 Mould heating

No. circuits fixed plate:

No. circuits movable plate:

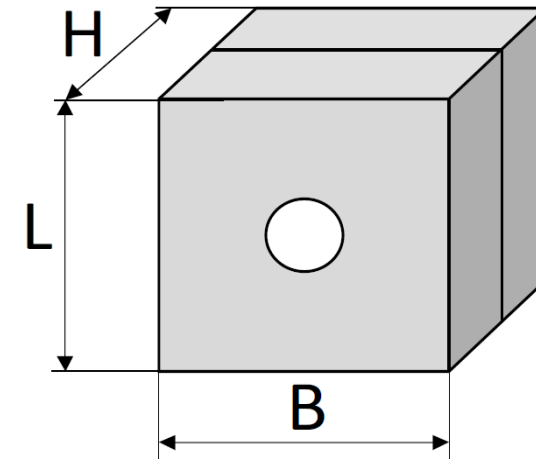



4. IMM Configuration

4.5 Minimum mould opening stroke:

4.6 Required clamp force:

4.7 Target output/h:

or part dimensions (projected area):



5. Dosing Equipment

5.1 Dosing equipment

Needed

Not needed

5.2 Preferred Supplier:

5.3 Size of barrel/hobcock

200 l

20 l

5.4 Colour

Percentage:

no colour

1-5%

6-10%

11-15%

>15%

5.5 Additional comments/needs:



6. Demolding

6.1 Falling parts

- Ejection
- Blow out

6.2 Automation

- Stripping
- Pull off
- Grapping

6.3 Brushing

- Brushing



7. Vacuum

7.1 Vacuum requested

Yes

No

7.2 Vacuum inlet

Movable plate

Fixed plate (SO)

7.3 Vacuum control

Movable plate

Fixed plate (SO)

In vacuum circuit

7.4 Vacuum pump

Yes

No

25l/min

40 l/min

60 l/min



8.Other

8.1 Further information/ needs:



SEND

For turnkey solution incl. Mould use LSR – turnkey – request from LSR