

The all-electric.

IntElect.

Sustainable - Precise - Efficient



***WORLD-LEADER
IN ALL-ELECTRIC
MACHINES***



The IntElect

Technology, expertise, experience and sustainability.

Sumitomo (SHI) Demag, the market leader in all-electric injection moulding machines, sets the highest benchmark in electrical machine engineering. Our targets are clear; maximum dynamics resulting in the highest level of efficiency and 100% production quality.

As a specialist manufacturer of injection moulding machines, we design and produce all of the core components for our electrical drive technology in-house. Because of this, our IntElect series delivers maximum dynamics and processing precision, resulting in optimal efficiency. Experience and test our technology, competence and experience for yourself.



The IntElect

Features and benefits at a glance.

Proprietary drive technology

We have our own research and development centre where our direct drives, converter technology and control system components are developed, tested and produced specifically for use in injection moulding machines. The result is the highest level of dynamics resulting in maximum processing precision, repeatability and production efficiency.

Comprehensive mould safety

The IntElect's new mould platens have been redesigned using finite element analysis. This provides up to 20% greater platen rigidity. Combined with the linear guides, this all helps to protect the longevity of the mould and protect against wear and tear.



Intuitive control

The IntElect control is intuitive to use and offers a variety of options for process monitoring and control. The logical and simple programming with pre-defined flexible machine sequences enables users to fully utilise the IntElect's numerous features to optimise productivity.

Investing in a sustainable future

The electrical energy consumed by injection moulding machines is converted into heat. Part of it directly, the other part indirectly via kinetic energy, deformation and friction. All of the heat generated must be dispersed and cooled. Naturally, less heat generated through powering the IntElect machine equals less cooling and consequently lowers the energy consumption. All of which naturally reduces the CO₂ footprint.



Efficiency

Application-based motor design.

Average 60% less energy consumption

The combination of in-house developed drive motors, frequency inverters, as well as the entire servomotor control system, has resulted in building one of the most energy-efficient injection moulding machines on the market. When compared to other injection moulding machines, the IntElect is proven to consume up to 80% less energy than hydraulic machines and 20% less energy than conventional all-electric machines.

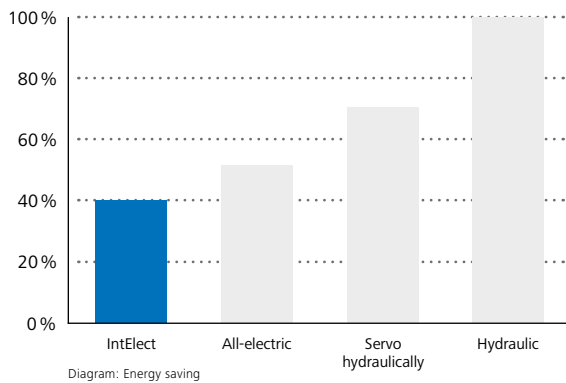

**LESS CONSUMPTION.
MORE POWER.**

CO₂ footprint

The basis for higher production output is higher machine availability, combined with dynamic, precise and parallel movements. Additionally, the high precision of the machine prevents the production of reject parts. The material savings are significant. Running at the optimum speed equals faster cycles, fewer process interruptions, increased productivity, and optimised production costs.

In-house drive technology

This level of dynamics, precision and efficiency cannot be accomplished using standard drive motors. Because the direct drives and controls on the IntElect series are precisely coordinated to match the machine, the IntElect achieves a response time of 0.1 ms. This is 20 times faster than conventional injection moulding machines and 1.000 times faster than the blink of a human eye.



act
SUSTAINABLY

Part quality

Delivering the highest quality standards.

Tightest tolerance process window

The use of direct drives means that mechanical losses are minimised. Compared to other drive technologies on the market, there are significantly fewer components to affect the transmission of forces. This combination of sophisticated control technology and additional efficiency modules are the basis for achieving the highest precision.

Long-term production stability

Due to our longstanding experience in manufacturing electric injection moulding machines, combined with the IntElect's own-brand drive concept, we are able to retain this constant process control throughout the service life of the machine. This advantage is especially important for maintaining compliance with validated process parameters.



***MAXIMUM DYNAMICS.
100% QUALITY.***

Dynamic injection movements

Combining high dynamics and speed means that the IntElect is able to process tight-tolerance engineering applications that many other full-electric injection moulding machines struggle to achieve.

Due to its unprecedented precision and repeatability, the IntElect can accommodate the widest selection of the most demanding moulding applications. Its highly dynamic acceleration and deceleration is critical to process stability, ensuring consistent production of higher quality parts. The rapid switch from injection to holding pressure also helps to eliminate burrs, resulting in minimal component defects.

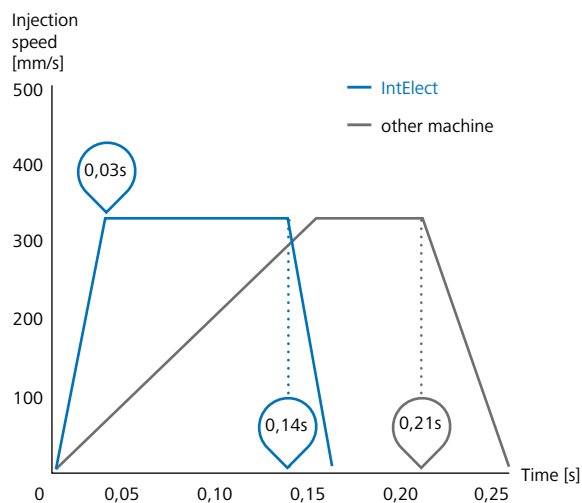
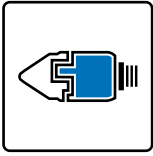

Diagram: Dynamics of the machine during injection



Part quality

Extra efficiency modules.



activeLock

Quality assurance

Our activeLock technology module makes it possible to reduce shot weight fluctuations by up to 60%. The switchable non-return valve prevents melt from flowing back into the plasticising cylinder at the beginning of the injection phase. Ensuring that your injection moulded parts are manufactured to the highest quality.

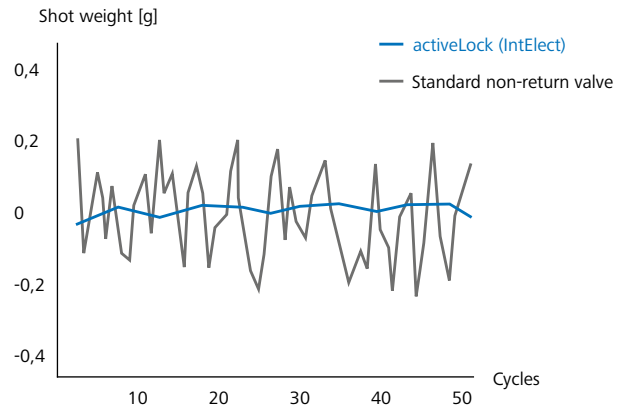
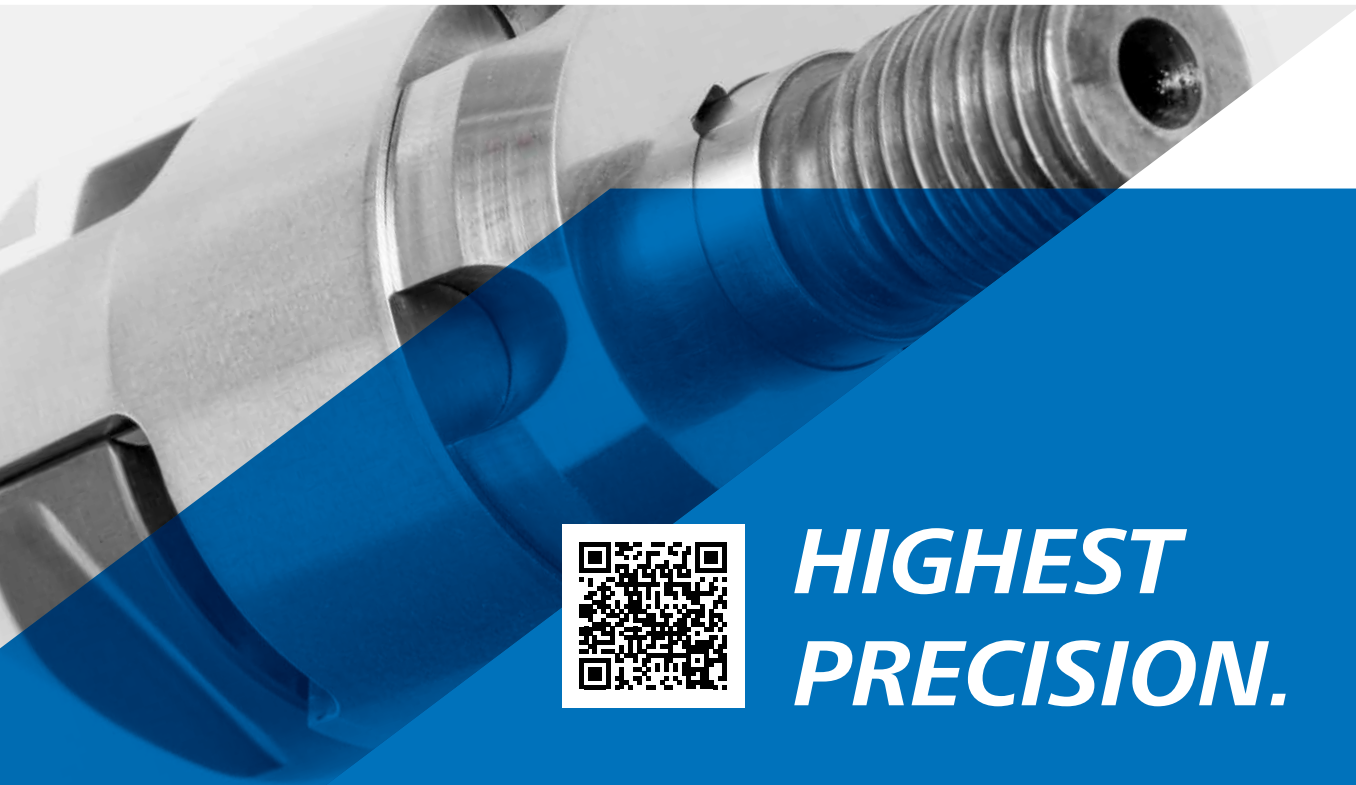

Diagram: Shot weight distribution per cycle



**HIGHEST
PRECISION.**



activeFlowBalance

Quality assurance

With activeFlowBalance, the negative effects of uneven mould filling are resolved, resulting in constant part quality when using multi-cavity moulds. Reducing reject rates and increasing the quality of your parts.

Part weight in shot [g]

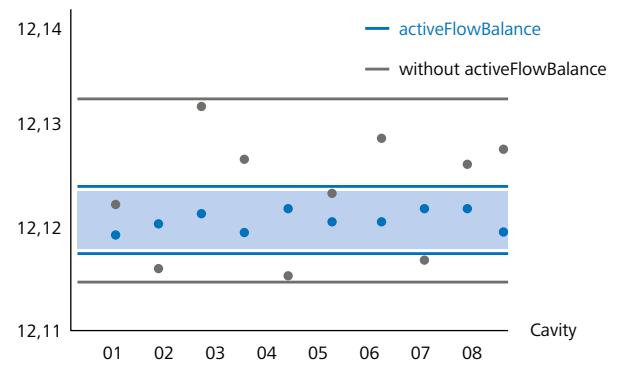

Diagram: Weight distribution in the individual cavities for an injection process



Mould protection

Maximum space with full safeguards.

Monitoring with profile

Our active mould protection solution, activeProtect, closely monitors the clamp force transmission during the mould closing sequence. Sensors are used to detect and transmit any changes to the force signature. Ensuring the safety of the mould isn't compromised. The smallest of objects can be detected. Additionally, the machine can graphically monitor the ejector force, as well as the injection pressure. All helping to mitigate damage to mould tools when operating machines at the fastest speed.

20% more space for moulds

Generously dimensioned linear guides combined with increased rigidity in the machine bed help to maintain maximum parallelism of the platens. This helps to minimise mould wear. Additionally, to accommodate larger injection moulds, the IntElect series from 200t upwards features a larger tie bar spacing; wider than comparable machines on the market. Boosting production capacity even further.

IntElect	220	280	350	450/500
Tie bar distance (h x v)	660x660	730x730	830x830	920x920



MAXIMUM TOOL PROTECTION.
MAXIMUM TIE BAR WIDTH.

20% more clamp platen rigidity

Applying finite element analysis, the IntElect series platens are optimised to the application to deliver more even distribution of the clamp force and as a result a more balanced distribution of pressure. Unlike conventional platens which can deform during locking (depending on the type and shape of the mould), our platens intelligently distribute the force flow in the platen. Resulting in up to 20% higher rigidity when compared to conventional platens.

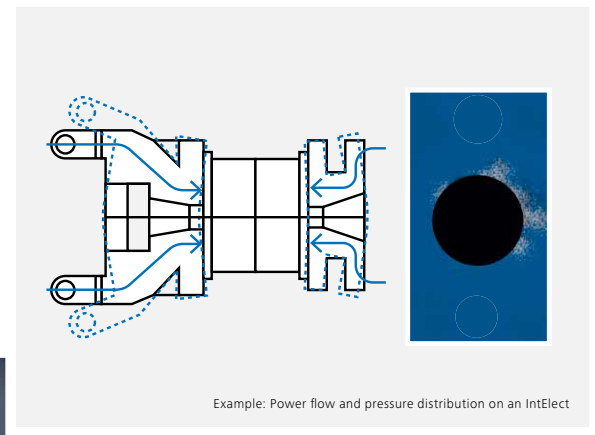
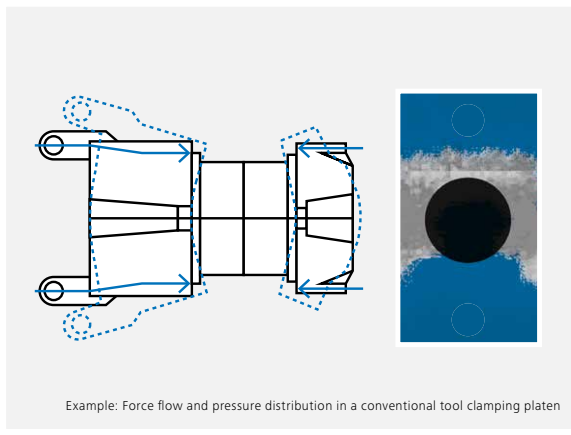

ON.

The IntElect S

More power for high speed applications.

Faster mould movements

Our direct drives are specifically optimised to support fast movement in high-speed applications and deliver minimum dry cycle times. The result of the increased performance on the IntElect S is a significant improvement in efficiency and production output rates.

Furthermore, the high performance drive spindles featured on the IntElect S are designed to extend the machine's service life, offering maximum reliability and machine availability.

Increased injection performance

Optimal injection speeds combined with advanced dynamics enables manufacturers to process a more expansive range of thin-walled applications. Further increasing your production flexibility while maintaining the highest quality of components.



Quicker ejector movements

Faster and stronger ejectors combined with quicker injection and metering speeds all help to optimise the motion sequences. Resulting in the fastest possible cycle times.

Minimum energy consumption

The highly optimised and low inertia direct drives on the IntElect S are designed specifically for fast cycle and extremely narrow tolerance applications. Featuring shorter high-performance spindles and encapsulated windings to improve heat transmission helps to ensure that the energy used to melt the polymer is minimal. Leading to higher output at the lowest ecological impact.

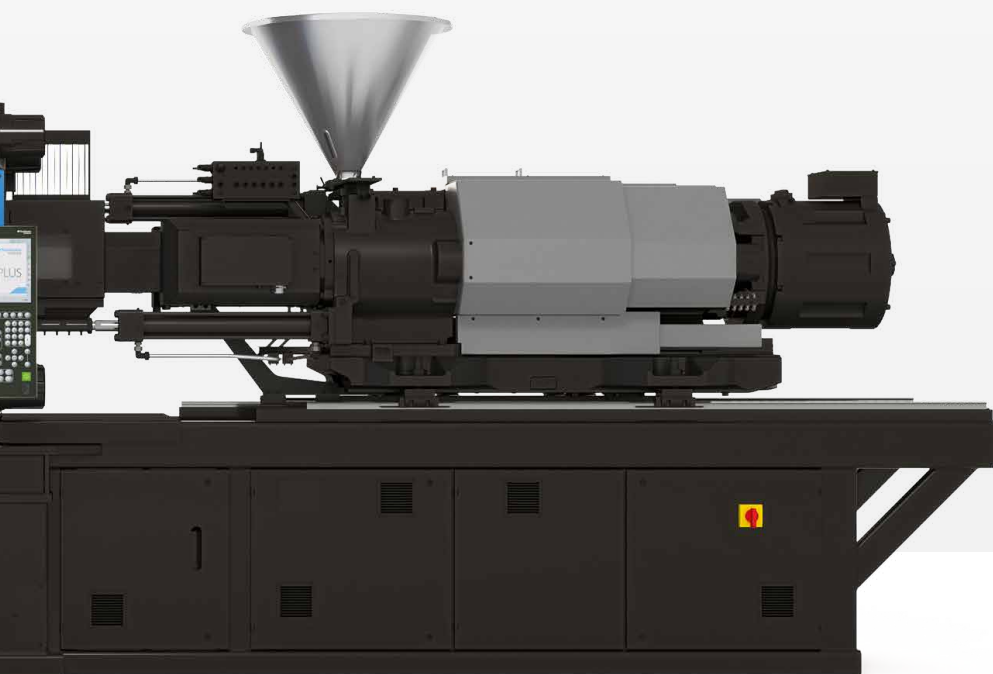

The IntElect multi

Flexing to your applications.

Additional injection unit

Expand your reach and range of global multi-component aesthetic applications, with our compact, energy efficient IntElect multi series. Offering double the moulding precision, from small to big shot weights, simultaneous to sequenced multi-component moulding.

Integrate multiple colours, resins and sensory/haptic features into products, while also benefiting from our long-standing processing, mould safety and direct drive experience. Sandwich moulding, foaming and fibre glass multi-component moulding are all feasible options.



Turntable integration

Reliant once again on our in-house developed drive technology geared towards top dynamics, precision and repeatability, our IntElect multi can be supplied with an integrated turntable. This option ensures the smoothest and fastest rotation of the mould between the injection of the first and second shot. Ensuring that cavities are perfectly positioned within 1 s of the turning time. Enabling production to continue immediately and without delay.

Improved mould space

Rather than opt for a larger machine to accommodate large moulds and a rotating turntable, the IntElect multi maintains its compactness by increasing the height, tie bar clearance and mould space. Delivering maximum flexibility and multi-component moulding precision, in the minimum footprint.



myConnect

Structure and construction. Modular Smart Factory platform.

myConnect is our answer to the digital age. The modular platform gives you access to a wide range of functions that enables you to react immediately in the event of a disruption to your production process. Additionally, you can easily access data in real-time, as well as access an extensive range of machine parameters. For example, you can view your production data at anytime, and from anywhere. On this technological basis, you can fall back on various parameters of the machine and, for example, visualize your production data anytime and anywhere.

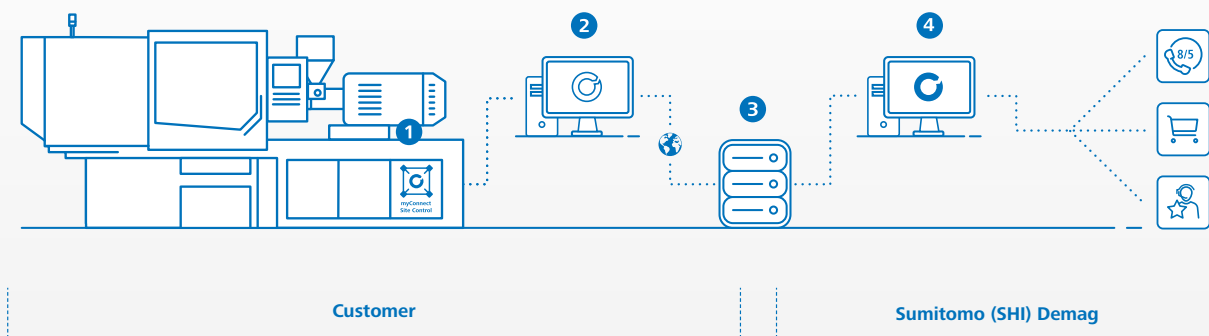

1 – Full connectivity

If several machines are in use, they are combined in one system. The network thus created can be accessed via both stationary and mobile devices. The queried data can also be aggregated across an entire location. So you always have your entire production in view.

2 – Secure connection

If a fault occurs, you can immediately Open Service Request myConnect provides a secure VPN tunnel a connection to the central Server and places a request in our Service message system. The TÜV IT certification for the Connection ensures maximum safety during Exchange of your data.

3 – Maximum data protection

The central server, which acts as an intermediary between the customer and Sumitomo (SHI) Demag, is operated exclusively in Germany and is subject to the strict data protection guidelines of the GDPR. An active connection is only established with the consent of both parties.

4 – Next level support

Once the connection is established, the complete digital service world of Sumitomo (SHI) Demag opens up to you. In addition to access to our extended live support functionalities, such as direct exchange with one of our service employees, - these also include access to our database for spare parts.





myConnect BASIC



myConnect Site Control

Hardware
(One-off investment)







-  **myConnectApp**
Always informed
-  **myDocumentation**
All digital
-  **myLiveCycleLog**
Full overview
-  **mySpareParts**
Original parts with one click
-  **mySupport**
Live support worldwide

Software
(Monthly charge)



myConnect PREMIUM

-  **mySmartVision**
Expert oversight for any given situation
+ One-off investment
-  **myApplicationExpert**
Know-how at the touch of a button
+ Monthly charge
-  **myMaintenance**
Cleverly planned
+ Monthly charge
-  **myProduction**
Complete control
+ Monthly charge
-  **mySupport Premium**
Always and everywhere
+ Monthly charge

Save up to 60% off the base price*

Subscription duration*	Number of machines**
Use longer and save!	The more machines, the lower the price.
1 year €€€€	€€€€ 
2 years €€€	€€€ 
3 years €€	€€ 
4 years €	€ 

*The graphics are only used to illustrate the offer and do not provide information about the exact cost savings! Please ask us directly about your price advantage.



www.sumitomo-shi-demag.eu

All of the information in this prospectus has been provided by us and collated with the greatest care. However, we cannot guarantee its accuracy. Furthermore, we must highlight that individual representations and information with regard to the actual delivery status may vary. 06.2023